

Cable Terminators

General Information

Purpose:

Cable Terminators and Sealing Fittings are used on conduit ends and cable ends to effectively seal the cable and conduit.

Where Installed:

- Wherever the jacket or sheath is removed from multi-conductor cable.
- Wherever it is desirable that the ends of conduit and cables be sealed against the entrance of water, damp or corrosive atmospheres, hot or cold air or dust.
- Wherever it is desirable to seal the entrance of exposed cable into cabinets, switchboards or terminal boxes.

Types:

Four basic types are offered as described below:

Figure 1: The Terminator body is deep enough to provide an ample compound chamber for use indoors or outdoors. A Canvas Bakelite Cover, either with or without taping cones, is provided to space and protect the cables. Instead of a cover, a female thread can be furnished for use with a short nipple or a flexible conduit adapter. The Terminator is recommended for sealing the ends of multi-conductor cables and for sealing the ends of conduit, and cables.

Figure 2: The Compound Bushing is more compact than the Terminator. Its compound chamber is not as deep. No cover or top thread is provided. It is for use in protected locations where space is limited.

Figure 3: The Sealing Bushing is similar to the compound Bushing except that a compound chamber is not provided. This fitting therefore is not recommended as a cable sealing device for use at the ends of multi-conductor cable. However, the conduit end is effectively sealed around the cable by neoprene gaskets for rubber type insulations. It is widely used to seal the ends of conduit against moisture, dust, corrosive atmospheres and objectionable gases. It is also used to seal conduit against the entrance of warm humid air which would otherwise condense inside the conduit.

Figure 4: These Conduit Sealing Bushings are used for sealing ends of conduit where cables emerge in applications involving higher fluid or gas pressures than can be handled by standard sealing bushings. These Conduit Sealing Bushings are compact and require only as much space inside a cabinet as an ordinary conduit bushing.

All of these illustrations show the Terminators and Sealing Fittings used with cable run in conduit. Each type is available for use with exposed cable. Terminators for many combinations of cable and conduit sealing devices other than those shown in the catalog can be made from standard parts. Information regarding such combinations to meet special job requirements will be gladly given on receipt of your request.

Water and Raintightness:

Terminators, Compound Bushings and Sealing fittings for cables having rubber types of insulations and jackets provide a watertight seal around the cables and at conduit ends, but the degree of seal at cabinet entrances depends on the type of cable entrance used. We invite inquiry regarding special sealing problems not covered in this catalog.

Voltage Ratings:

Since the insulation on the individual conductor is not disturbed in the terminator, it is not subject to a voltage rating any more than the conduit on which it is used. Furthermore, the DOZSEAL Insulating Compounds which are recommended for use in these devices have high dielectric strength. (See Page RA15 for listing of compounds.) Their use improves the insulation of the cable within the terminator and eliminates the possibility of any air or moisture being in contact with the cable insulation at this point.

Termination made with O-Z/Gedney Terminators are suitable for use at the voltage rating of the cable being used provided terminating kits are used where required.

Other Terminators:

- See Catalog Sections TA and TB for Armored Cable and Metal Clad Cable Terminators.
- See Catalog Section BC for Hazardous Location Metal Clad Cable Terminators.
- See Catalog Section QA for Cable Support Products.

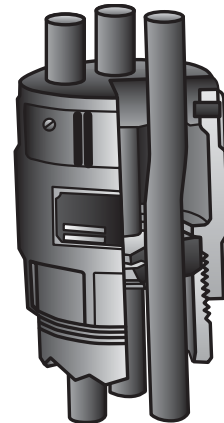

Figure 1

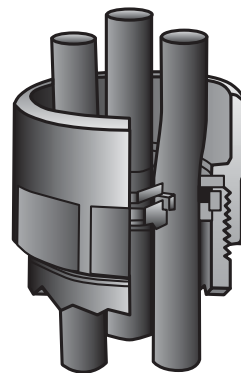

Figure 2

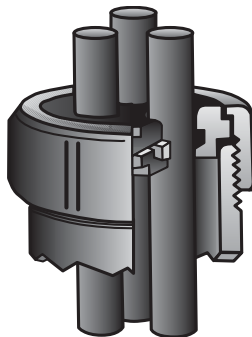

Figure 3

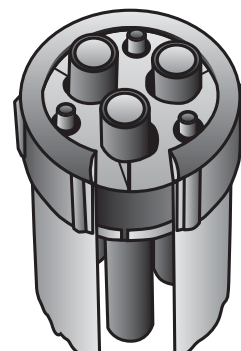

Figure 4

Cable Terminators

Assembly Procedure

Blank Sealing Bushings and Terminators Containing Discs:

There are many types of fittings containing Bakelite discs and O-rings which can be safely drilled in the field by following our detailed instructions. "These fittings will perform satisfactorily only when properly machined to the actual dimensions for the specific O.D. of cable used. Detailed instruction sheets containing layout data and special assembly procedures are supplied with blank fittings. Failure to comply may result in compound leakage and/or loss of seal around cable. O-Z/Gedney is not responsible for any field machined or modified fittings."

Other Terminators:

- See Catalog Sections TA and TB for Armored Cable and Metal Clad Cable Terminators.
- See Catalog Section BC for Hazardous Location Metal Clad Cable Terminators.
- See Catalog Section QA for Cable Support Products.

The basic principles used throughout the line of O-Z/Gedney Terminators covering their use with Rubber Covered Cables are clearly illustrated in this assembly.

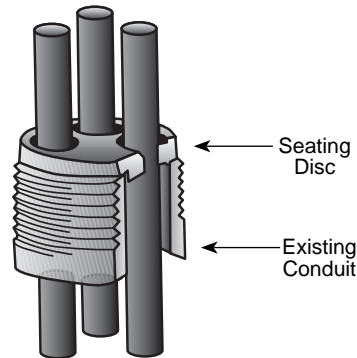

1 After cables are prepared, Bakelite seating disc with properly drilled holes is slipped over cables and set into the conduit.

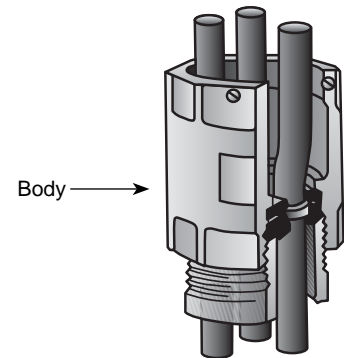

4 The body is then screwed directly on the conduit, clamping the discs and applying pressure to the neoprene rings.

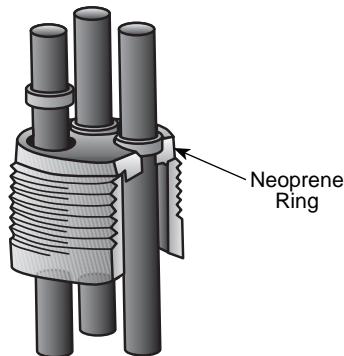

2 Neoprene rings, are placed around the cables and set into recesses in the seating disc.

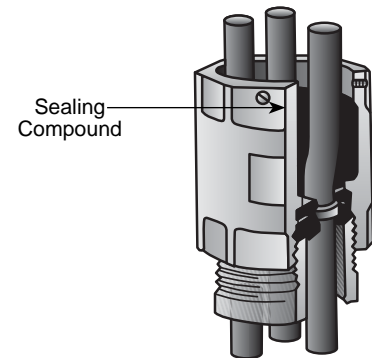

5 Compound is heated to the proper temperature and the body filled to the height of the set screws, making a complete seal.

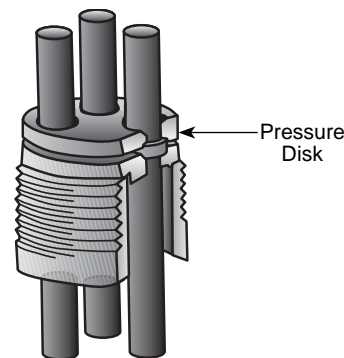

3 A Canvas Bakelite pressure disc is passed over the cables and set on top of the neoprene rings, holding them firmly in place.

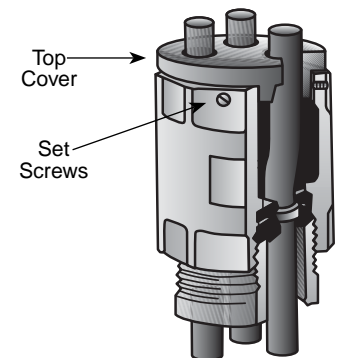

6 Before compound sets, Canvas Bakelite top cover is passed over the conductors, pushed down into the hot compound and secured by set screws.

Cable Terminators

With Compound Chamber For Threaded Rigid Conduit

Type CRC

With Top Cover

Type CRN

With Top Thread

Use:

To effectively seal one or more single or multiple conductor cables and the conduit against the entrance of water, damp or corrosive atmospheres, hot or cold air or dust.

Features:

- For rubber or plastic insulated cables in rigid conduit.
- Provides an ample sealing compound chamber for use indoors or outdoors.
- For applications involving IMC, EMT or PVC conduit, a short nipple of rigid conduit should be used entering the bottom threaded hub.
- For Sealing Compound, see page RA15. Sealing Compound is not included and must be ordered separately.
- Can be field-drilled, see page RA2.
- For voltage ratings, see page RA1.

Material/Finish:

Body: Malleable or Ductile Iron Casting with Hot Dip Galvanized finish.
Sealing Disc: Canvas Bakelite

Options:

- Body available in Cast Aluminum. Add suffix "A" to standard catalog number.
- Fittings can be furnished for more than four wires or wires of varying sizes.
- Lay-In-Lug™ Grounding Lug can be mounted on Terminator Body, see page QA14.
- Type CRC terminators are available with tapping cones for sealing rubber or plastic insulated cables.
- Due to the possibility of Magnetic Induction Heating, a single alternating current conductor should not be used in iron fittings. Specify optional Aluminum material, see above.
- Contact your local representative for price and availability on above options.

Third Party Certification:

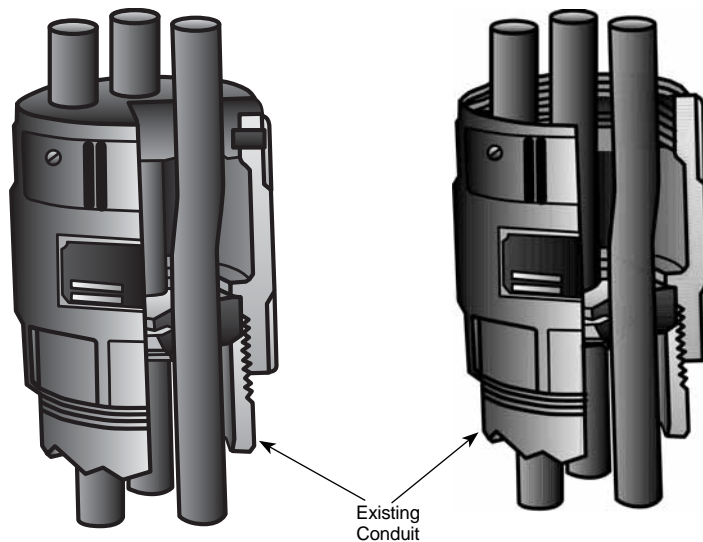
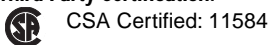

Type CRC

Type CRN

TYPE CRC						Dim. in Inches		Approx. Compound Req'd. (Pints)
Conduit Size	Max. Diameter of Wire Permitted - Inches 1* Wire	2 Wires	3 Wires	4 Wires	Catalog Number	Max. Dia.	Overall Height	
1¼"	1.02	.55	.50	.44	CRC-125	2¼	3⅞	⅞
1½"	1.20	.63	.59	.51	CRC-150	2⅝	3¾	⅞
2"	1.53	.81	.73	.65	CRC-200	3	3¾	¼
2½"	1.83	.97	.93	.78	CRC-250	3½	4¼	½
3"	2.28	1.21	1.16	.97	CRC-300	4¼	4¾	¾
3½"	2.65	1.40	1.34	1.12	CRC-350	4¾	5⅞	1
4"	3.00	1.58	1.52	1.27	CRC-400	5⅞	5⅞	1½
5"	3.75	1.99	1.91	1.60	CRC-500	6½	6½	2¾
6"	4.50	2.39	2.30	1.92	CRC-600	7⅞	6⅞	4

TYPE CRN						Dim. in Inches		Approx. Compound Req'd. (Pints)	
Conduit Size	Max. Diameter of Wire Permitted - Inches 1* Wire	2 Wires	3 Wires	4 Wires	Catalog Number	Top Th'd. Pipe Size	Max. Dia.		Overall Height
1¼"	1.02	.55	.50	.44	CRN-125	1¼	2¼	3⅞	⅞
1½"	1.20	.63	.59	.51	CRN-150	1½	2⅝	3¾	⅞
2"	1.53	.81	.73	.65	CRN-200	2	3	3¾	¼
2½"	1.83	.97	.93	.78	CRN-250	2½	3⅞	4¼	½
3"	2.28	1.21	1.16	.97	CRN-300	3	4¼	4¾	¾
3½"	2.65	1.40	1.34	1.12	CRN-350	3½	4¾	5⅞	1
4"	3.00	1.58	1.52	1.27	CRN-400	4	5⅞	5⅞	1½
5"	3.75	1.99	1.91	1.60	CRN-500	5	6½	6½	2¾
6"	4.50	2.39	2.30	1.92	CRN-600	6	6	6⅞	4

TO ORDER SPECIFY:

- 1 Catalog Number
- 2 Number of cables
- 3 Diameter over insulation of each cable

Wire Armor Cable Terminators

For Exposed Wire Armor Cable

Type CRA

With Compound Chamber

Use:

To effectively seal a single or multiple conductor cable with exposed wire armor against the entrance of water, damp or corrosive atmospheres, hot or cold air or dust.

Features:

- Supplied with Locknut and Insulated Bushing for enclosure knockout entrance.
- Provides an ample sealing compound chamber for use indoors or outdoors.
- For Sealing Compound, see page RA15. Sealing Compound is not included and must be ordered separately.
- Can be field-drilled, see page RA2.
- For voltage ratings, see page RA1.

Material/Finish:

Body: Malleable or Ductile Iron Casting with Hot Dip Galvanized finish.
Sealing Disc: Canvas Bakelite

Options:

- Body available in Cast Aluminum. Add suffix "A" to standard catalog number.
- Due to the possibility of Magnetic Induction Heating, a single alternating current conductor should not be used in iron fittings. Specify optional Aluminum material, see above.
- Lay-In-Lug™ Grounding Lug can be mounted on Terminator Body, see page QA14.
- Contact your local representative for price and availability on above options.

TO ORDER SPECIFY:
 1 Catalog Number
 2 Diameter Over Armor
 3 Diameter Over Jacket Under Armor

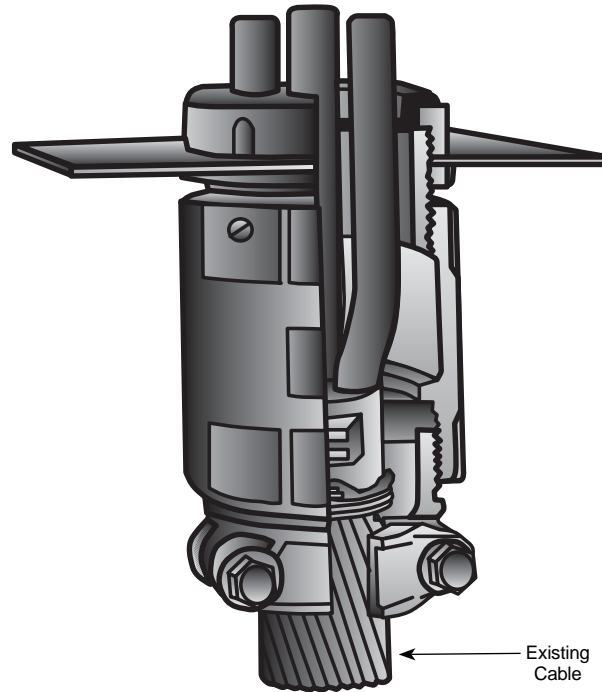

Type CRA

Cable Range		Knockout Size Required	Catalog Number	Dia. Body	Dia. Bushings	Dimensions in Inches		Approx. Compound Req'd. Pints
Min.	Max.					Height Outside Box	Height Inside Box	
.89	1.31	1½	CRA-150	2¾	2¾	4¾	¾	¼
1.32	1.66	2	CRA-200	3	2¾	5¼	7/8	½
1.67	2.40	3	CRA-300	4¼	4	6½	1	1¼
2.41	3.13	4	CRA-400	5½	5	7¾	1½	2¾
3.14	3.88	5	CRA-500	6½	6¼	8¾	1¾	4½

Cable Terminators

For Threaded Rigid Conduit – Mounted Horizontally

Type CRH

With Compound Chamber

Use:

To effectively seal one or more single or multiple conductor cables. Prevents the escape of compound, regardless of its position.

Features:

- The head end of the terminator is equipped with a pressure bushing which compresses neoprene rings placed around the cables between two Canvas Bakelite Discs. The Type CRH is similar in interior construction to the Type CRC on Page RA3 of this section.
- For rubber or plastic insulated cables in rigid conduit.
- Provides an ample sealing compound chamber for use indoors or outdoors.
- For applications involving IMC, EMT or PVC conduit, a short nipple of rigid conduit should be used entering the bottom threaded hub.
- For Sealing Compound, see page RA15. Sealing Compound is not included and must be ordered separately.
- Can be field-drilled, see page RA2.

Material/Finish:

Body: Malleable or Ductile Iron Casting with Hot Dip Galvanized finish.
Sealing Disc: Canvas Bakelite

Options:

- Body available in Cast Aluminum. Add suffix "A" to standard catalog number.
- Fittings can be furnished for more than four wires or wires of varying sizes.
- Due to the possibility of Magnetic Induction Heating, a single alternating current conductor should not be used in iron fittings. Specify optional Aluminum material, see above.
- Lay-In-Lug™ Grounding Lug can be mounted on Terminator Body, see page QA14.
- Contact your local representative for price and availability on above options.

Third Party Certification:

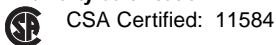

TO ORDER SPECIFY:
 1 Catalog Number
 2 Number of conductors
 3 Diameter over insulation of each conductor

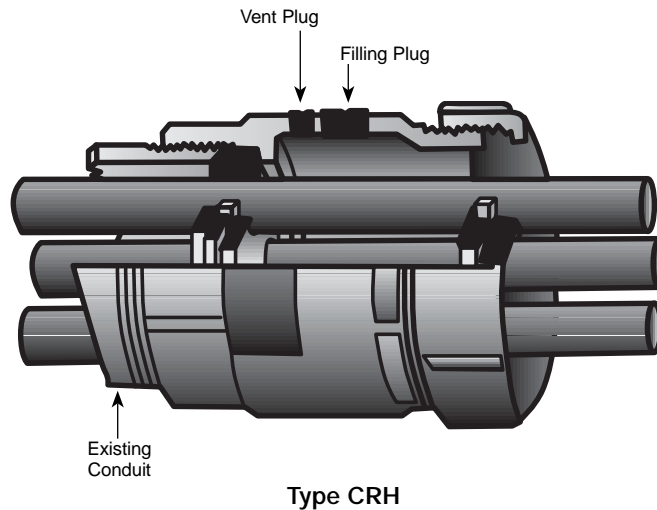

Conduit Size	Max. Diameter of Wire Permitted – Inches				Catalog Number	Dim. in Inches		Approx. Compound Req'd. Pints
	1* Wire	2 Wires	3 Wires	4 Wires		Maximum Diameter	Overall Height	
1¼"	1.02	.58	.50	.44	CRH-125	2¾"	3¾"	⅓
1½"	1.20	.63	.59	.51	CRH-150	2¾"	3½"	⅓
2"	1.53	.81	.73	.65	CRH-200	3¾"	4¾"	¼
2½"	1.83	.97	.93	.78	CRH-250	3¾"	4¾"	½
3"	2.28	1.21	1.16	.97	CRH-300	3¾"	4¾"	½
3½"	2.65	1.40	1.34	1.12	CRH-350	5½"	5½"	1
4"	3.00	1.58	1.52	1.27	CRH-400	5¾"	6¾"	1½
5"	3.75	1.99	1.91	1.60	CRH-500	6¾"	6¾"	2¼
6"	4.50	2.39	2.30	1.92	CRH-600	7¾"	7¾"	4

Cable Terminators

For Threaded Rigid Conduit Compound Chamber with Top and Taping Cones

Type DTC - Standard Size

Type DRC - Expanded Size

Use:

- To effectively seal one or more conductors and the conduit against the entrance of water, damp or corrosive atmospheres, hot or cold air or dust.
- **Type DTC** is used where the wires installed in the conduit are small enough to provide proper space between the cones for taping, in a Terminator the same size as the conduit.
- **Type DRC** is used where larger wires are installed in the same size conduit. With the larger wires, enough space must be allowed between the cones for taping. This condition calls for a special adapter with a larger body and cover.

Features:

- For rubber or plastic insulated cables in rigid conduit.
- Specially designed Canvas Bakelite cover with Taping Cones.
- Provides an ample sealing compound chamber for use indoors or outdoors.
- For applications involving IMC, EMT or PVC conduit, a short nipple of rigid conduit should be used entering the bottom threaded hub.
- For Sealing Compound, see page RA15. Sealing Compound is not included and must be ordered separately.
- Can be field-drilled, see page RA2.
- For voltage ratings, see page RA1.

Material/Finish:

Body: Malleable or Ductile Iron Casting with Hot Dip Galvanized finish.

Sealing Disc: Canvas Bakelite

Options:

- Body available in Cast Aluminum. Add suffix "A" to standard catalog number.
- Fittings can be furnished for more than four wires or wires of varying sizes.
- Due to the possibility of Magnetic Induction Heating, a single alternating current conductor should not be used in iron fittings. Specify optional Aluminum material, see above.
- Lay-In-Lug™ Grounding Lug can be mounted on Terminator Body, see page QA14.
- Contact your local representative for price and availability on above options.

Third Party Certification:

 CSA Certified: 11584

TO ORDER SPECIFY:
 1 Catalog Number
 2 Number of cables
 3 Diameter over insulation of each cable

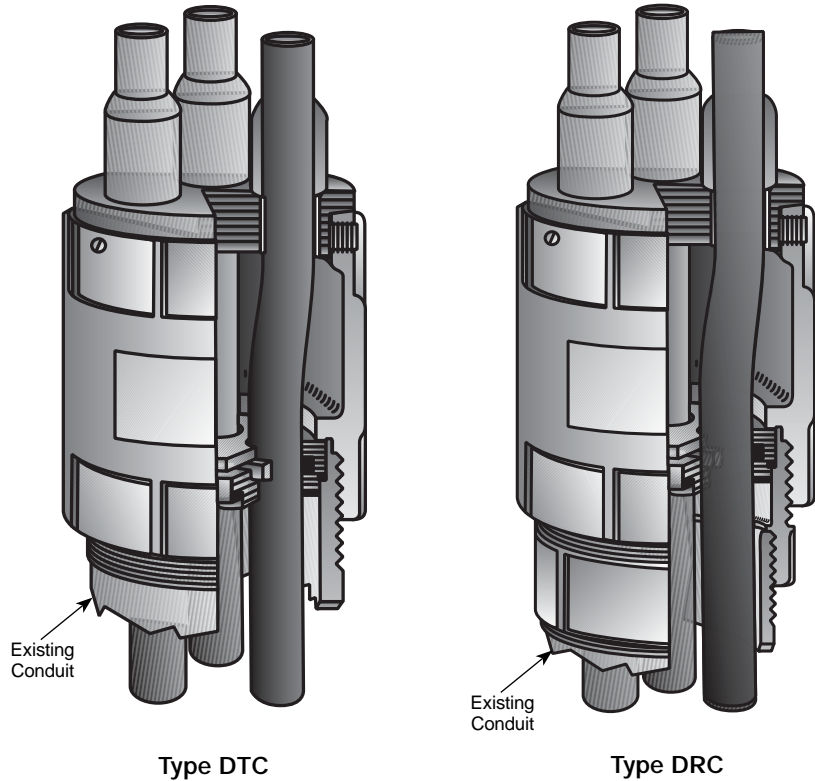

Conduit Size	Max. Diameter of Wire Permitted - Inches				Catalog Number	Dim. in Inches		Approx. Compound Req'd. Pints
	1* Wire	2 Wires	3 Wires	4 Wires		Maximum Diameter	Overall Height	
1½"	1.20	.47	.44	.34	DTC-150	2¾	4	⅞
1½"	1.34	.63	.59	.51	DRC-150	3	5¼	¼
2"	1.53	.63	.59	.51	DTC-200	3	4¾	¼
2"	1.63	.81	.78	.65	DRC-200	3½	6⅞	½
2½"	1.83	.81	.78	.65	DTC-250	3½	5⅞	½
2½"	2.00	.97	.93	.78	DRC-250	4¼	7⅞	¾
3"	2.28	.97	.93	.78	DTC-300	4¼	6	¾
3"	2.42	1.21	1.16	.97	DRC-300	4¾	8⅞	1
3½"	2.65	1.25	1.16	.97	DTC-350	4¾	6⅞	1
3½"	2.85	1.40	1.34	1.12	DRC-350	5⅞	9⅞	1½
4"	3.00	1.40	1.34	1.12	DTC-400	5¾	7⅞	1½
4"	3.15	1.58	1.52	1.27	DRC-400	5¼	9½	2
5"	3.75	1.81	1.71	1.50	DTC-500	6½	8¼	2¾
5"	3.90	1.99	1.91	1.60	DRC-500	7⅞	10¼	4
6"	4.50	2.38	2.00	1.75	DTC-600	7⅞	8⅞	4

Conduit Compound Bushings

For Ends of Threaded Rigid Conduit

Type FR

Use:

To effectively seal one or more single or multiple conductor cables against the entrance of water, damp or corrosive atmospheres, hot or cold air or dust.

Features:

- For rubber or plastic insulated cables in rigid conduit.
- Provides an ample sealing compound chamber for use indoors or outdoors.
- For Sealing Compound, see page RA15. Sealing Compound is not included and must be ordered separately.
- For applications involving IMC, EMT or PVC conduit, a short nipple of rigid conduit should be used entering the bottom threaded hub.
- For voltage ratings, see page RA1.
- Lay-In-Lug™ Grounding Lug can be mounted on Terminator Body, see page QA14.
- Can be field-drilled, see page RA2.

Material/Finish:

Bodies 1" & 1¼" are Steel with Zinc Electroplate. Larger Bodies are Malleable or Ductile Iron with Hot Dip Galvanized finish. Sealing Discs are Canvas Bakelite.

Options:

- Bodies are available in Aluminum. Add suffix "A" to standard catalog number.
- Steel Bodies 1" & 1¼" are available with Hot Dip Galvanized Finish.
- Fittings can be furnished for more than four wires or wires of varying sizes.
- Due to the possibility of Magnetic Induction Heating, a single alternating current conductor should not be used in iron fittings. Specify optional Aluminum material, see above.
- Contact your local representative for price and availability on above options.

Third Party Certification:



CSA Certified: 11584

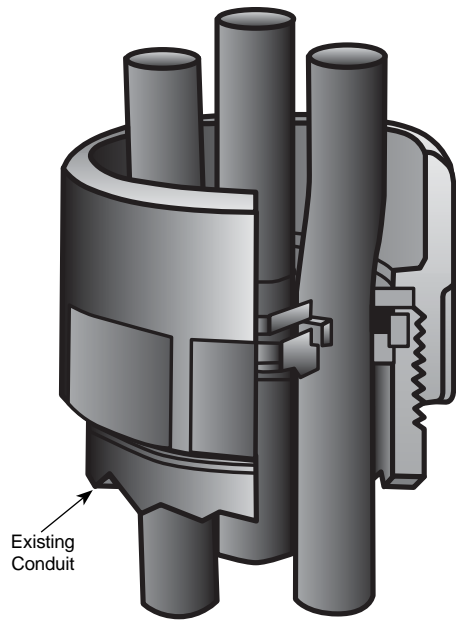

Type FR

TO ORDER SPECIFY:

- 1 Catalog Number
- 2 Number of cables
- 3 Diameter over insulation of each cable

Conduit Size	Max. Diameter of Wire Permitted - Inches				Catalog Number	Dim. in Inches		Approx. Compound Required Pints
	1* Wire	2 Wires	3 Wires	4 Wires		Max. Dia.	Overall Height	
1"	.78	.38	.34	.31	FR-100	1¼	1%	½ ₂₀
1¼"	1.02	.55	.50	.44	FR-125	2⅞	1¼	½ ₂₀
1½"	1.20	.63	.59	.51	FR-150	2⅝	1⅞	⅓
2"	1.53	.81	.73	.65	FR-200	3	2	⅓
2½"	1.83	.97	.93	.78	FR-250	3⅞	2½	⅓
3"	2.28	1.21	1.16	.97	FR-300	4⅞	2⅞	½
3½"	2.65	1.40	1.34	1.12	FR-350	4⅞	2⅞	½
4"	3.00	1.58	1.52	1.27	FR-400	5⅞	2⅞	⅓
5"	3.75	1.99	1.91	1.60	FR-500	6¾	3⅞	1
6"	4.50	2.39	2.30	1.92	FR-600	7⅞	3⅞	1½ ₁₂

Cabinet Compound Bushings

For Threaded Rigid Conduits Entering Cabinets

Type HRK

Use:

To effectively seal one or more single or multiple conductor cables against the entrance of water, damp or corrosive atmospheres, hot or cold air or dust.

Features:

- For rubber or plastic insulated cables in rigid conduit.
- Provides an ample sealing compound chamber for use indoors or outdoors.
- For Sealing Compound, see page RA15. Sealing Compound is not included and must be ordered separately.
- Supplied with two locknuts for cabinets up to 1/2" thick.
- For applications involving IMC, EMT or PVC conduit, a short nipple of rigid conduit should be used entering the bottom threaded hub.
- For voltage ratings, see page RA1.
- Lay-In-Lug™ Grounding Lug can be mounted on Terminator Body, see page QA14.
- Can be field-drilled, see page RA2.

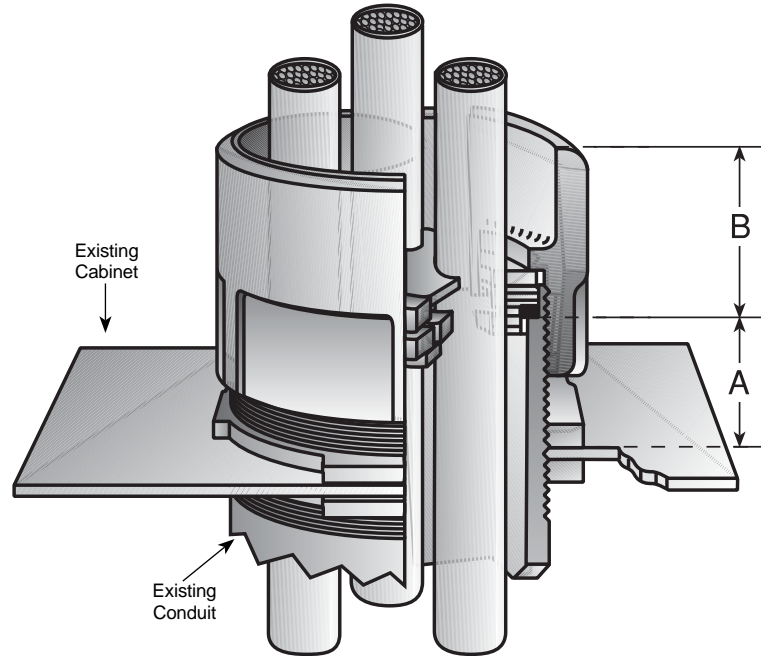

Type HRK

Material/Finish:

Bodies 1" & 1 1/4" are Steel with Zinc Electroplate. Larger Bodes are Malleable or Ductile Iron with Hot Dip Galvanized finish. Locknuts are Steel or Malleable Iron with Zinc Electroplate. Sealing Discs are Canvas Bakelite.

Options:

- Bodies are available in Aluminum. Add suffix "A" to standard catalog number.
- Bodies 1" & 1 1/4" are available with Hot Dip Galvanized Finish.
- Fittings can be furnished for more than four wires or wires of varying sizes.
- Due to the possibility of Magnetic Induction Heating, a single alternating current conductor should not be used in iron fittings. Specify optional Aluminum material, see above.
- Contact your local representative for price and availability on above options.

Third Party Certification:



CSA Certified: 11584

TO ORDER SPECIFY:

- 1 Catalog Number
- 2 Number of cables
- 3 Diameter over insulation of each cable

Conduit Size	Max. Diameter of Wire Permitted - Inches				Catalog Number	Dimensions in Inches			Approx. Compound Required Pints
	1* Wire	2 Wires	3 Wires	4 Wires		Max. Dia.	"A" Min.	"B"	
1"	.78	.38	.34	.31	HRK-100	1 1/4	1	1 1/8	1/20
1 1/4"	1.02	.55	.50	.44	HRK-125	2 3/8	1	1 1/4	1/20
1 1/2"	1.20	.63	.59	.51	HRK-150	2 5/8	1	1 1/4	1/8
2"	1.53	.81	.73	.65	HRK-200	3 1/8	1 1/8	1 1/2	1/8
2 1/2"	1.83	.97	.93	.78	HRK-250	3 5/8	1 3/8	1 3/4	1/8
3"	2.28	1.21	1.16	.97	HRK-300	4 3/8	1 1/2	1 7/8	1/2
3 1/2"	2.65	1.40	1.34	1.12	HRK-350	5	1 1/2	1 7/8	1/2
4"	3.00	1.58	1.52	1.27	HRK-400	5 1/2	1 1/2	1 7/8	3/8
5"	3.75	1.99	1.91	1.60	HRK-500	6 1/8	1 3/4	2 3/8	1
6"	4.50	2.39	2.30	1.92	HRK-600	7 1/8	1 3/4	2 1/2	1 1/2

Cabinet Compound Bushings

For Exposed Cables Entering Cabinets

Type HRE

Use:

To effectively seal one or more single or multiple conductor cables against the entrance of water, damp or corrosive atmospheres, hot or cold air or dust.

Features:

- For rubber or plastic insulated cables.
- Provides an ample sealing compound chamber for use indoors or outdoors.
- For Sealing Compound, see page RA15. Sealing Compound is not included and must be ordered separately.
- Supplied with a locknut and neoprene sealing ring for cabinets up to 1/4" thick.
- For voltage ratings, see page RA1.
- Lay-In-Lug™ Grounding Lug can be mounted on Terminator Body, see page QA14.
- Can be field-drilled, see page RA2.

Material/Finish:

Bodies 1" & 1 1/4" are Steel with Zinc Electroplate. Larger Bodes are Malleable or Ductile Iron with Hot Dip Galvanized finish. Locknut is Steel or Malleable Iron with Zinc Electroplate. Sealing Discs are Canvas Bakelite.

Options:

- Bodies are available in Aluminum. Add suffix "A" to standard catalog number.
- Bodies 1" & 1 1/4" are available with Hot Dip Galvanized Finish.
- Fittings can be furnished for more than four wires or wires of varying sizes.
- Due to the possibility of Magnetic Induction Heating, a single alternating current conductor should not be used in iron fittings. Specify optional Aluminum material, see above.
- Contact your local representative for price and availability on above options.

Third Party Certification:

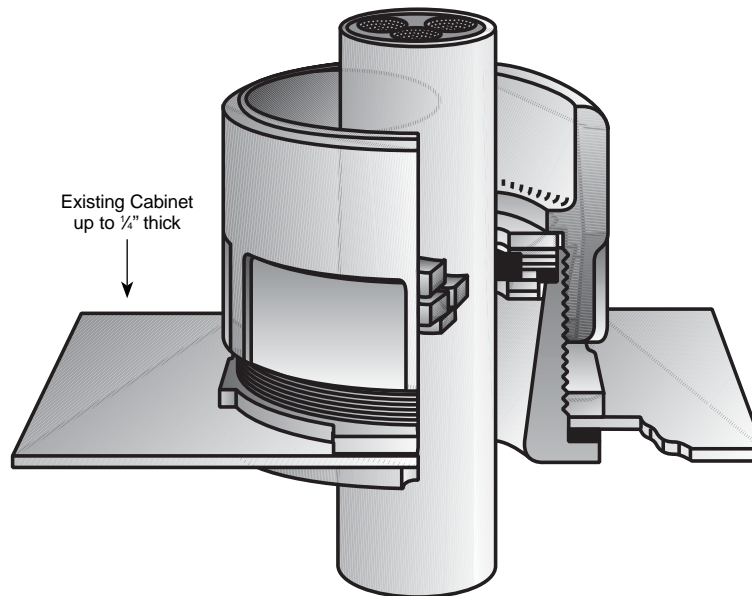
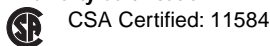

Type HRE

TO ORDER SPECIFY:

- 1 Catalog Number
- 2 Number of conductors
- 3 Diameter over insulation of each conductor

Max. Dia. of Wire Permitted – Inches					Knockout Size	Catalog Number	Dim. in Inches		Approx. Compound Required Pints
1* Wire	2 Wires	3 Wires	4 Wires	Max.Overall Dia.			Height		
.78	.38	.34	.31	1"	HRE-100	1 1/4	2 1/8	1/20	
1.02	.55	.50	.44	1 1/4"	HRE-125	2 3/8	2 1/4	1/20	
1.20	.63	.59	.51	1 1/2"	HRE-150	2 3/8	2 1/4	1/8	
1.53	.81	.73	.65	2"	HRE-200	3 1/8	2 3/8	1/8	
1.83	.97	.93	.78	2 1/2"	HRE-250	3 3/8	3 3/8	1/3	
2.28	1.21	1.16	.97	3"	HRE-300	4 3/8	3 3/8	1/2	
2.65	1.40	1.34	1.12	3 1/2"	HRE-350	5	3 3/8	1/2	
3.00	1.58	1.52	1.27	4"	HRE-400	5 1/2	3 3/8	2/3	
3.75	1.99	1.91	1.60	5"	HRE-500	6 3/8	4	1	
4.50	2.39	2.30	1.92	6"	HRE-600	7 3/8	4 1/4	1 1/2	

Cable Support Compound Bushings

For Exposed Cables Entering Cabinets - with p0Zi-grip® Wedging Plug

Type HPE

Use:

Provides cable support while effectively sealing one or more single or multiple conductor cables against the entrance of water, damp or corrosive atmospheres, hot or cold air or dust.

Features:

- For rubber or plastic insulated cables.
- Supports a vertical length of cable per NEC Section 300.19(A). Refer to page QA1 for details.
- Provides an ample sealing compound chamber for use indoors or outdoors.
- For Sealing Compound, see page RA15. Sealing Compound is not included and must be ordered separately.
- Supplied with a locknut and neoprene sealing ring for cabinets up to 1/4" thick.
- For voltage ratings, see page RA1.
- Lay-In-Lug™ Grounding Lug can be mounted on Compound Chamber, see page QA14.

Material/Finish:

Bodies 1" & 1 1/4" are Steel with Zinc Electroplate. Larger Bodes are Malleable or Ductile Iron with Hot Dip Galvanized finish. Locknut is Steel or Malleable Iron with Zinc Electroplate. Wedging Plug is Canvas Bakelite. Locknuts available in aluminum when ordering aluminum bodies.

Options:

- Bodies are available in Aluminum. Add suffix "A" to standard catalog number.
- Bodies 1" & 1 1/4" are available with Hot Dip Galvanized Finish.
- Fittings can be furnished for two or more wires or wires of varying sizes.
- Due to the possibility of Magnetic Induction Heating, a single alternating current conductor should not be used in iron fittings. Specify optional Aluminum material, see above.
- Contact your local representative for price and availability on above options.

Third Party Certification:



CSA Certified: 11584

TO ORDER SPECIFY:

- 1 Catalog Number
- 2 Number of cables
- 3 Diameter over insulation of each cable

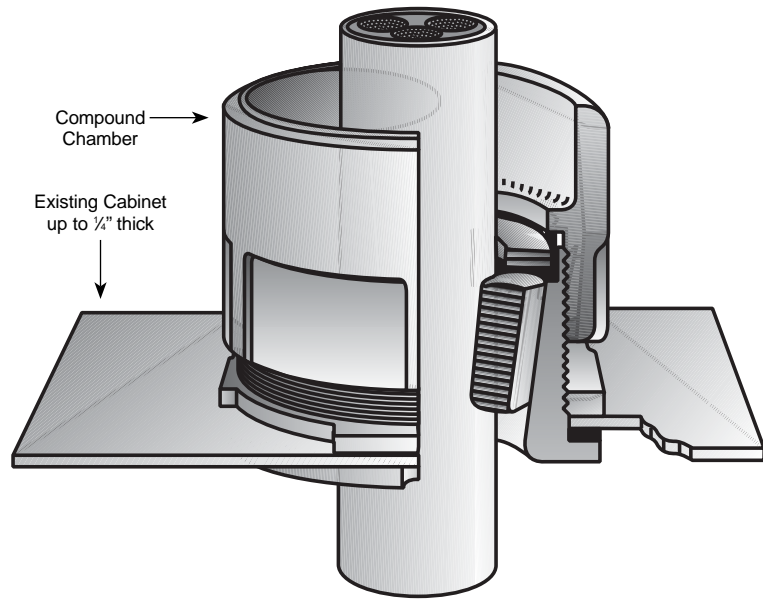

Type HPE with Canvas Bakelite Wedging Plug

Cable support plugs will not be supplied undrilled.

Max. Cable Dia. (inches)	Knockout Size	Catalog Number	Dim. in Inches		Approx. Compound Required Pints
			Max. Dia.	Height Inside Box	
.68	1"	HPE-100	1 1/4	2 1/8	1/20
.93	1 1/4"	HPE-125	2 1/8	2 1/4	1/20
1.20	1 1/2"	HPE-150	2 5/8	2 1/4	1/6
1.53	2"	HPE-200	3 3/8	2 5/8	1/6
1.83	2 1/2"	HPE-250	3 3/8	3 3/8	1/3
2.28	3"	HPE-300	4 3/8	3 3/8	1/2
2.65	3 1/2"	HPE-350	5	3 3/8	1/2
3.00	4"	HPE-400	5 1/2	3 3/8	2/3
3.75	5"	HPE-500	6 3/8	4	1
4.50	6"	HPE-600	7 3/8	4 1/4	1 1/2

Cable support plugs will not be supplied undrilled.

Sealing Bushings for Conduit

For Ends of Threaded Rigid Conduits

Type KR

Use:

Provides a seal at the top of a vertical conduit for one or more single or multiple conductor cables. Excludes water, damp or corrosive atmospheres, hot or cold air or dust.

Features:

- For rubber or plastic insulated cables in rigid conduit.
- For voltage ratings, see page RA1.
- Lay-In-Lug™ Grounding Lug can be mounted on Locking Collar, see page QA14.
- Can be field-drilled, see page RA2.
- For applications involving IMC, EMT or PVC conduit, a short nipple of rigid conduit should be used entering the bottom threaded hub.

Material/Finish:

Locking Collar is Malleable or Ductile Iron with Hot Dip Galvanized finish. Sealing Discs are Canvas Bakelite.

Options:

- Locking Collar is available in Aluminum. Add suffix "A" to standard catalog number.
- Fittings can be furnished for more than four wires or wires of varying sizes.
- Due to the possibility of Magnetic Induction Heating, a single alternating current conductor should not be used in iron fittings. Specify optional Aluminum material, see above.
- Contact your local representative for price and availability on above options.

Third Party Certification:

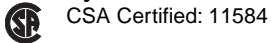

TO ORDER SPECIFY:

- 1 Catalog Number
- 2 Number of cables
- 3 Diameter over insulation of each cable

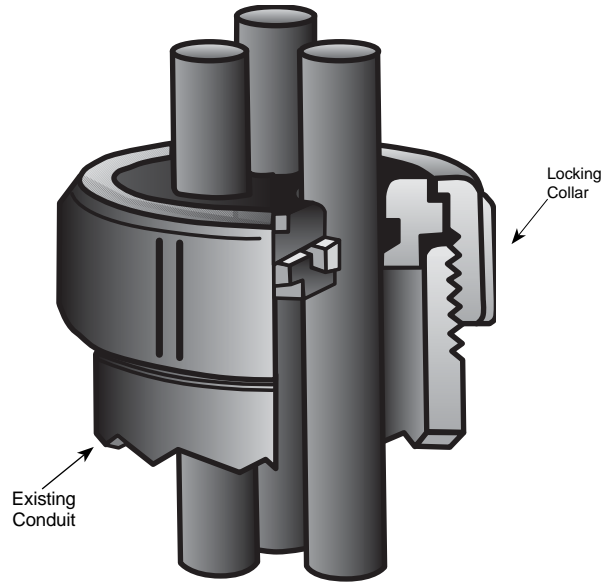

Type KR

Conduit Size	Max. Diameter of Wire Permitted - Inches				Catalog Number	Dim. in Inches	
	1* Wire	2 Wires	3 Wires	4 Wires		Max. Dia.	Overall Height
1"	.78	.38	.34	.31	KR-100	1 ⁵ / ₈	1
1 ¹ / ₄ "	1.02	.55	.50	.44	KR-125	1 ⁷ / ₈	1 ¹ / ₈
1 ¹ / ₂ "	1.20	.63	.59	.51	KR-150	2 ³ / ₈	1 ¹ / ₈
2"	1.53	.81	.73	.65	KR-200	2 ¹³ / ₁₆	1 ¹ / ₈
2 ¹ / ₂ "	1.83	.97	.93	.78	KR-250	3 ³ / ₈	1 ³ / ₈
3"	2.28	1.21	1.16	.97	KR-300	4	1 ¹ / ₂
3 ¹ / ₂ "	2.65	1.40	1.34	1.12	KR-350	4 ¹ / ₂	1 ¹ / ₂
4"	3.00	1.58	1.52	1.27	KR-400	5 ¹ / ₈	1 ³ / ₈
5"	3.75	1.99	1.91	1.60	KR-500	6 ¹ / ₄	1 ³ / ₄
6"	4.50	2.39	2.30	1.92	KR-600	7 ³ / ₈	1 ³ / ₄

Cabinet Sealing Bushings

For Ends of Threaded Rigid Conduits Entering Cabinets

Type GRK

Use:

Provides a seal at the top of a vertical conduit entering a cabinet, for one or more single or multiple conductor cables. Excludes water, damp or corrosive atmospheres, hot or cold air or dust.

Features:

- For rubber or plastic insulated cables in rigid conduit.
- Supplied with two locknuts for cabinets up to ¼" thick.
- For voltage ratings, see page RA1.
- Lay-In-Lug™ Grounding Lug can be mounted on Locking Collar, see page QA14.
- Can be field-drilled, see page RA2.
- For applications involving IMC, EMT or PVC conduit, a short nipple of rigid conduit should be used entering the bottom cabinet siphole.

Material/Finish:

Locking Collar is Malleable or Ductile Iron with Hot Dip Galvanized finish. Locknuts are Steel or Malleable Iron with Zinc Electroplate. Sealing Discs are Canvas Bakelite.

Options:

- Locking Collar and Conduit Locknuts are available in Aluminum. Add suffix "A" to standard catalog number.
- Fittings can be furnished for more than four wires or wires of varying sizes.
- Due to the possibility of Magnetic Induction Heating, a single alternating current conductor should not be used in iron fittings. Specify optional Aluminum material, see above.
- Contact your local representative for price and availability on above options.

Third Party Certification:

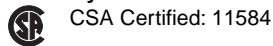

TO ORDER SPECIFY:
 1 Catalog Number
 2 Number of cables
 3 Diameter over insulation of each cable

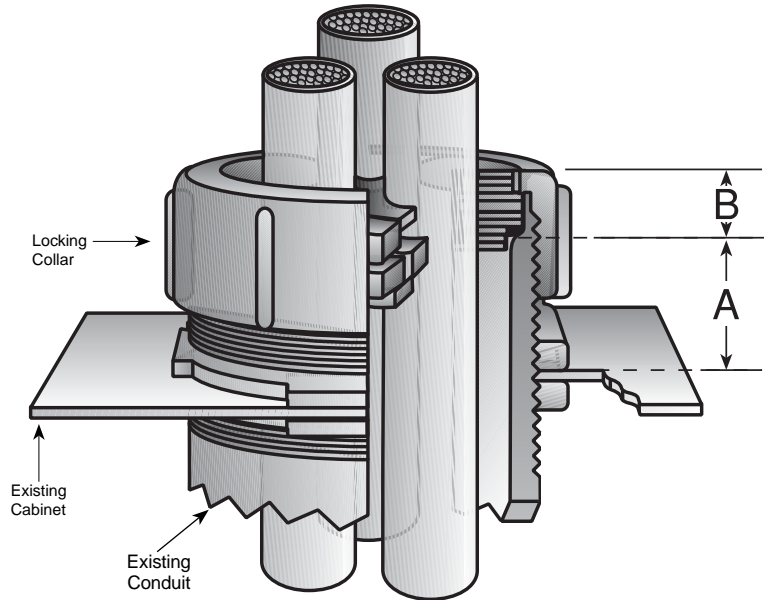

Type GRK

Conduit Size	Max. Diameter of Wire Permitted - Inches				Catalog Number	Dim. in Inches		
	1* Wire	2 Wires	3 Wires	4 Wires		Max. Dia.	"A" Min.	"B"
1"	.78	.38	.34	.31	GRK-100	1¼	1	½
1¼"	1.02	.55	.50	.44	GRK-125	2⅞	1	½
1½"	1.20	.63	.59	.51	GRK-150	2⅞	1	½
2"	1.53	.81	.73	.65	GRK-200	3⅞	1⅞	½
2½"	1.83	.97	.93	.78	GRK-250	3⅞	1⅞	⅝
3"	2.28	1.21	1.16	.97	GRK-300	4⅞	1⅞	⅝
3½"	2.65	1.40	1.34	1.12	GRK-350	5	1½	¾
4"	3.00	1.58	1.52	1.27	GRK-400	5½	1½	¾
5"	3.75	1.99	1.91	1.60	GRK-500	6⅞	1⅞	1
6"	4.50	2.39	2.30	1.92	GRK-600	7⅞	1¾	1

Cabinet Sealing Bushing

For Exposed Cables Entering Cabinets

Type GRE

Use:

To effectively seal one or more single or multiple conductor cables against the entrance of water, damp or corrosive atmospheres, hot or cold air or dust.

Features:

- For rubber or plastic insulated cables.
- Supplied with a Zinc Electroplated Locknut and Neoprene Sealing Ring for cabinets up to 1/4" thick.
- For voltage ratings, see page RA1.
- Lay-In-Lug™ Grounding Lug can be mounted on Locking Collar, see page QA14.
- Can be field-drilled, see page RA2.

Material/Finish:

Locking Collar and Body is Malleable or Ductile Iron with Hot Dip Galvanized finish. Sealing Discs are Canvas Bakelite.

Options:

- Locking Collar, Body and Locknuts are available in Aluminum. Add suffix "A" to standard catalog number.
- Fittings can be furnished for more than four wires or wires of varying sizes.
- Due to the possibility of Magnetic Induction Heating, a single alternating current conductor should not be used in iron fittings. Specify optional Aluminum material, see above.
- Contact your local representative for price and availability on above options.

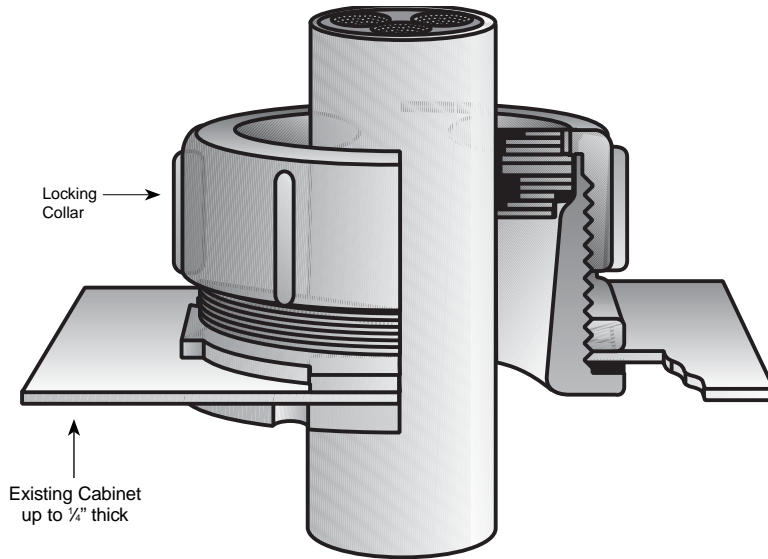

Type GRE

Third Party Certification:



CSA Certified: 11584

Applicable Third Party Standards:

CSA Standard: C22.2 No. 18

TO ORDER SPECIFY:

- 1 Catalog Number
- 2 Number of conductors
- 3 Diameter over insulation of each conductor

Max. Dia. of Wire Permitted - Inches					Catalog Number	Dim. in Inches	
1* Wire	2 Wires	3 Wires	4 Wires	Knockout Size		Max. Dia.	Overall Height
.78	.38	.34	.31	1"	GRE-100	1 1/4	1 1/2
1.02	.55	.50	.44	1 1/2"	GRE-125	2 3/8	1 5/8
1.20	.63	.59	.51	1 1/2"	GRE-150	2 3/8	1 5/8
1.53	.81	.73	.65	2"	GRE-200	3 1/8	1 5/8
1.83	.97	.93	.78	2 1/2"	GRE-250	3 3/8	2
2.28	1.21	1.16	.97	3"	GRE-300	4 3/8	2 1/8
2.65	1.40	1.34	1.12	3 1/2"	GRE-350	5	2 1/4
3.00	1.58	1.52	1.27	4"	GRE-400	5 1/2	2 3/8
3.75	1.99	1.91	1.60	5"	GRE-500	6 3/8	2 5/8
4.50	2.39	2.30	1.92	6"	GRE-600	7 3/8	3

*Not CSA Approved.

Cable Support Cabinet Bushing

For Exposed Cables Entering Cabinets - with pOzi-grip® Wedging Plug

Type GPE

Use:

Provides cable support for one or more single or multiple conductor cables entering a cabinet or enclosure.

Features:

- For rubber or plastic insulated cables.
- Supports a vertical length of cable per NEC Section 300.19(A). Refer to page QA1 for details.
- For information pertaining to "R" type Cable Supports, please refer to pages QA1, QA2 and QA5.
- Supplied with a Zinc Electroplated Locknut for cabinets up to ¼" thick.
- Lay-In-Lug™ Grounding Lug can be mounted on Locking Collar, see page QA14.
- Cable Support Plugs cannot be field-drilled.

Material/Finish:

Locking Collar and Body is Malleable or Ductile Iron with Hot Dip Galvanized finish. Pressure Disc and Wedging Plug are Canvas Bakelite.

Options:

- Bodies are available in Aluminum. Add suffix "A" to standard catalog number.
- Fittings can be furnished for more than four wires or wires of varying sizes.
- Due to the possibility of Magnetic Induction Heating, a single alternating current conductor should not be used in iron fittings. Specify optional Aluminum material, see above.
- Contact your local representative for price and availability on above options.

Third Party Certification:



CSA Certified: 11584

Applicable Third Party Standards:

CSA Standard: C22.2 No. 18

TO ORDER SPECIFY:

- 1 Catalog Number
- 2 Number of conductors
- 3 Diameter over insulation of each conductor

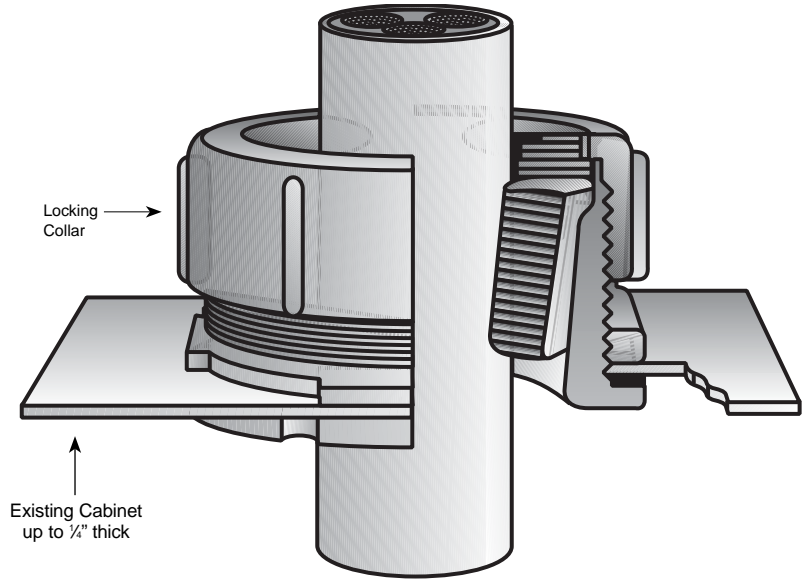

Type GPE with Canvas Bakelite Wedging Plug

Cable support plugs will not be supplied undrilled.

Max. Cable Dia. (inches)	Knockout Size	Catalog Number	Dim. in Inches	
			Max. Dia.	Height Inside Box
.68	1"	GPE-100	1 1/4	1 1/2
.93	1 1/4"	GPE-125	2 3/8	1 5/8
1.20	1 1/2"	GPE-150	2 7/8	1 5/8
1.53	2"	GPE-200	3 3/8	1 5/8
1.83	2 1/2"	GPE-250	3 5/8	2
2.28	3"	GPE-300	4 3/8	2 1/8
2.65	3 1/2"	GPE-350	5	2 1/4
3.00	4"	GPE-400	5 1/2	2 3/8
3.75	5"	GPE-500	6 3/8	2 3/8
4.50	6"	GPE-600*	7 3/8	3

*Not CSA Approved.

Cable support plugs will not be supplied undrilled.

DOZSeal Sealing Insulating Compound

For Use in Terminators, Compound Bushings and Compound Type Cable Supports

DOZseal 220 is a universal medium-soft asphaltic base compound having a low softening point and low pouring temperature. The compound remains plastic at low temperatures and remains viscose at the highest cable operating temperature.

Used In:

Gasketed or Threaded Splice Fittings and Gasketed Terminators.

Use in Non-Hazardous Location With:

Any cable having solid type insulation, such as Paper, Varnished Cambric, Rubber, Butyl, Cross-Linked Polyethylene, or High Molecular weight Polyethylene rated 34.5KV and below.

DOZseal 225 is a high ambient medium-hard asphaltic base compound having a medium-low softening point and a low pouring temperature. The compound remains plastic at medium-low temperatures and remains more viscose at the highest cable operating temperature.

Used In:

Gasketed or Threaded Splice Fittings and Gasketed Terminators, when they are installed in hot climates or in hot exposures.

Use in Non-Hazardous Location

With:

Cables having solid type insulation, such as Paper, Varnished Cambric, Rubber, and Butyl rated 34.5KV and below.

DOZseal 230 is a hard asphaltic base compound having a high softening point and high pouring temperature. The compound remains plastic at the highest cable operating temperature.

Used In:

Non-Gasketed Terminators or Cable Supports.

Use in Non-Hazardous Location With:

Any cable having solid type insulation.

FOR USE IN TERMINATORS, COMPOUND BUSHINGS, COMPOUND TYPE CABLE SUPPORTS				
Compound Number	Type	Catalog Number One Qt. Can	One Gal. Bucket	Five Gal. Bucket
DOZSEAL 220	Medium-soft asphaltic base	DOZ-220Q	DOZ-220G	DOZ-220G5
DOZSEAL 225	Medium-hard asphaltic base	DOZ-225Q	DOZ-225G	DOZ-225G5
DOZSEAL 230	Hard asphaltic base	DOZ-230Q	DOZ-230G	DOZ-230G5

For shipping purposes, the approximate gross weight of the above compounds is 10 lbs. per gallon.

NOTE: When ordering Compound specify by number of units only, not quarts or gallons.

Example: To order 50 gallons of DOZSEAL 220 specify ten (10) DOZ-220G5 units.

Characteristics	Unit	CHARACTERISTICS		
		DOZSEAL Filling Compounds		
		DOZSEAL 220	DOZSEAL 225	DOZSEAL 230
Softening Point	°F	115-125	165-170	230-240
Pouring Temperature	°F	325-375	325-375	375-400
Flash Point	°F	475	475	475
Dielectric Strength	KV	50	50	55

Conduit Sealing Bushings

Type CSB

For use with Cable

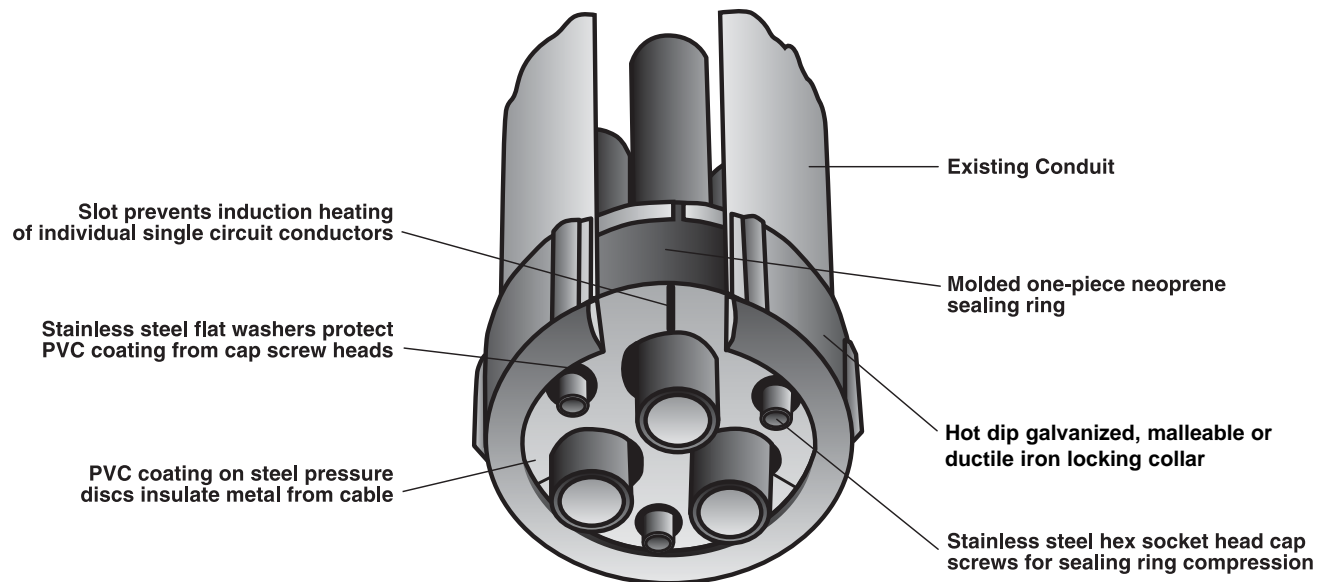

Details of Construction:

Pressure Discs: Thick metal discs with custom drilled holes to accommodate cables. Steel discs are slotted at cable holes to eliminate induction heating effect of single conductor alternating current. Steel discs are PVC coated for corrosion protection, to insulate cable holes and to prevent plates from bridging to other ferrous parts. Uncoated aluminum plates are available. Copper alloy, stainless steel or phenolic discs are available at price addition.

Screws & Washers: Corrosion-proof stainless steel socket head screws are used to compress the two discs against the sealing ring. Hex head stainless steel machine screws are available. PVC coated discs have stainless steel washers to prevent screws from damaging coating. (Suffix - P type only.)

Locking Collar: Malleable iron hot dip galvanized; suffix "A" for aluminum. Gaskets are provided to prevent locking collar and end of conduit from damaging PVC coated disc. (Suffix - P type only.)

Sealing Ring: Thick one-piece neoprene ring custom drilled. Neoprene is specifically compounded for the following operating characteristics:

1. Low compression modulus (the ability of the neoprene sealing ring to seal with low-tightening force).
2. Very low compression set (maintain seal over extended period without having to retighten).
3. Anti-oxidant (resistance to ozone attack).
4. Anti-oxidant (resistance to weathering).
5. Low crystallization (suitable for use at low temperatures).
6. Fire retardant (will not support combustion).

For modifications or special requirements, contact your local representative for price and availability.

Conduit Sealing Bushings

For Use with Insulated Wire, Cable and Rigid Metal Conduit

Type CSB Series

Type CSBE:

Seals against pressure from the outside of the fitting and to provide some support for the cables when fitting is used in vertical position as shown in illustration.

Type CSBI:

Seals against fluids or gases that are inside a conduit and prevents them from entering an enclosure.

Type CSBG:

Provides all the features of Types CSBE and CSBI and in addition prevents the sealing bushing from moving out of the end of the conduit should the internal pressure be high or if the fitting is used on conduit in an inverted position. The Type CSBG fittings are capable of sealing against gas or fluid pressure of 100 psig, (non-segmented) Type CSBI and CSBE – 50 psig (non-segmented.) Segmenting reduces above pressure in half. Can also be supplied with Lay-In-Lug grounding wire connector, see page QA14.

Use:

- These conduit Sealing Bushings are used for sealing the ends of conduit in applications involving higher static gas or fluid pressures than can be handled by standard sealing bushings.
- For use with IMC or EMT, a short nipple of Rigid Metal Conduit should be used to accommodate the Conduit Sealing Bushing. For Schedule 40 PVC Conduit, contact your local representative.

Features:

- The complete assembly is provided with 1 or multiple holes to accommodate the size and number of cables which emerge from the conduit. When the fitting is in place and the screws are tightened, the neoprene sealing ring is compressed between the metal plates and is forced against the inside wall of the conduit and also against the cable insulation to effect a complete seal at the conduit end.

- Blank fittings are available. These are intended as abandonment devices only. **Do not field drill.**
- Consult your local representative for all other applications.
- These fittings are simple to install. They eliminate the special preparation of the end of the conduit or the compounding of the conduit thread which is required on other types of sealing fittings used to seal against high pressures.

Materials:

Slotted PVC coated steel discs, neoprene sealing ring and stainless steel socket head cap screws and washers. Locking collars on type CSBG are hot dipped galvanized malleable or ductile iron.

Optional Materials:

Also available with aluminum or brass/bronze pressure discs (Metal Plates) on Type CSBI and CSBE bushings. To specify, substitute suffix "A" or "B" for "P" in catalog number. (Example: CSBI-200A-1) Locking Collar and Pressure Discs are also available in Aluminum or Bronze on Type CSBG Bushings. Example (CSBG-200A-1) Consult your local representative for price and availability.

Alternate Construction: (Catalog # SEG)

Segmented Design – Segmental pressure discs and slit-neoprene sealing ring produce a come-apart design which allows the sealing bushing to be installed without having to thread it along the cable or allows installation around cables already pulled.

Also available with slit neoprene sealing ring and one piece pressure discs.

Third Party Certification:

UL Listed: E-11857
 Type CSBG is Listed by Underwriters Laboratories, Inc. as an outlet bushing, service entrance seal or service head.

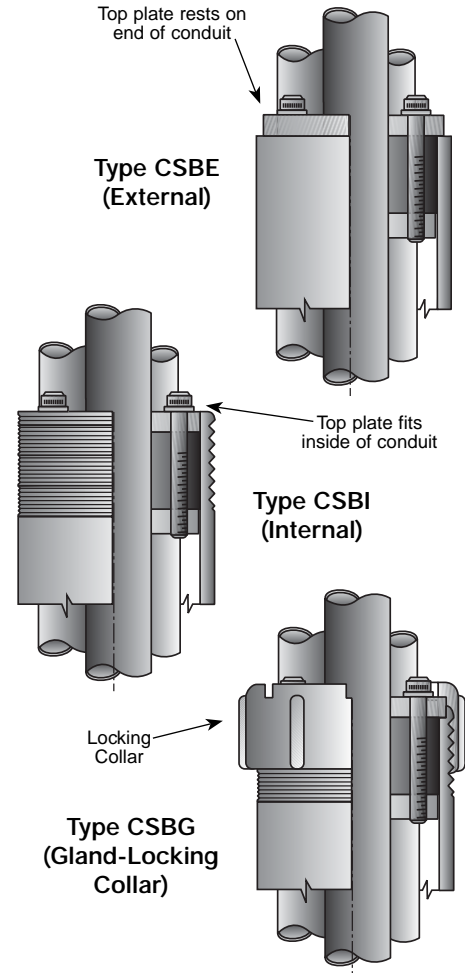

TO ORDER SPECIFY:
 1 Catalog Number
 2 Conduit Size
 3 Number of Cables
 4 Outside Diameters of Cables Over Insulation
 5 Segmented, if Required
 6 Two Neoprene Sealing Rings, if required (prices on application). Suffix G-2.

Conduit Size	Max. Diameter of Wire Permitted - Inches				Type CSBE Catalog Number		Type CSBI Catalog Number		Type CSBG Catalog Number	
	1 Wire	2 Wires	3 Wires	4 Wires	Blank†	One to Four Wires	Blank†	One to Four Wires	Blank†	One to Four Wires
1½"	.78	.59	.54	.44	CSBE-150P-0	CSBE-150P-1	CSBI-150P-0	CSBI-150P-1	CSBG-150P-0	CSBG-150P-1
2"	.89	.77	.71	.59	CSBE-200P-0	CSBE-200P-1	CSBI-200P-0	CSBI-200P-1	CSBG-200P-0	CSBG-200P-1
2½"	1.32	.96	.89	.78	CSBE-250P-0	CSBE-250P-1	CSBI-250P-0	CSBI-250P-1	CSBG-250P-0	CSBG-250P-1
3"	1.89	1.26	1.13	.96	CSBE-300P-0	CSBE-300P-1	CSBI-300P-0	CSBI-300P-1	CSBG-300P-0	CSBG-300P-1
3½"	2.13	1.38	1.38	1.13	CSBE-350P-0	CSBE-350P-1	CSBI-350P-0	CSBI-350P-1	CSBG-350P-0	CSBG-350P-1
4"	2.63	1.63	1.51	1.26	CSBE-400P-0	CSBE-400P-1	CSBI-400P-0	CSBI-400P-1	CSBG-400P-0	CSBG-400P-1
5"	3.45	2.00	1.88	1.63	CSBE-500P-0	CSBE-500P-1	CSBI-500P-0	CSBI-500P-1	CSBG-500P-0	CSBG-500P-1
6"	4.32	2.44	2.21	2.07	CSBE-600P-0	CSBE-600P-1	CSBI-600P-0	CSBI-600P-1	CSBG-600P-0	CSBG-600P-1

† Blank fittings are intended as abandonment and future use devices only. Blank fittings cannot be field drilled.

Conduit Sealing Bushings

Type CSB Series

1 Segmental Design (Figure 1):

Segmental pressure discs and slit neoprene sealing ring produce a come-apart design which allows the sealing bushing to be installed without having to thread it along the cable or allows installation around cables already terminated. Maximum diameter of wire or cable may need to be reduced. (Include Catalog Number "SEG"). Also available with slit neoprene sealing ring and one piece pressure discs.

2 Double Sealing Ring:

A second neoprene sealing ring may be added for cable support applications. Add suffix "G2" to catalog number. Contact your local representative for price and availability.

3 Close/Short Nipples:

Short nipples which can be screwed into conduit hubs or couplings. Seal Fittings are then installed in the open ends of these nipples. To specify a fitting complete with nipple add "N" after Catalog Number. (Example: CSBG 200P-N).

4 Type GL Cabinet Adapter (Figure 2):

For use with sealing bushings when exposed wires enter cabinets. Hot dip galvanized malleable or ductile iron is standard; aluminum if specified. Adapter assembly includes special smooth bore nipple, gasket and locknut. Type GL Cabinet Adapters must be ordered separately. See table for catalog numbers.

Thread length on special smooth bore nipples will accommodate 1/8" thick cabinet or structure on Type CSBG (specify if thicker than 1/8"), and up to 3/4" thickness on Types CSBE & CSBI.

These fittings are designed for use in schedule 40 Rigid Metal Conduit. For use with IMC or EMT, a short nipple of Rigid Metal Conduit should be used to accommodate the Conduit Sealing Bushing. Contact your local representative for application involving Schedule 40 or Schedule 80 PVC Conduit.

Blank fittings are intended as abandonment and future use devices only. DO NOT FIELD DRILL.

Dimensional Data:
See Page RA19

Type CSBE
Segmental Design
Figure 1

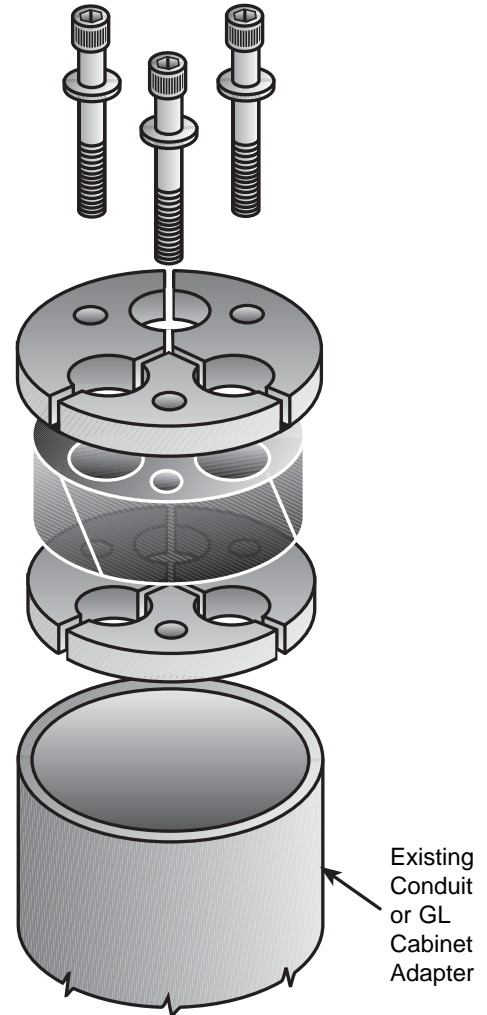

Conduit Size	Catalog Number
1½	GL150
2	GL200
2½	GL250
3	GL300
3½	GL350
4	GL400
5	GL500
6	GL600

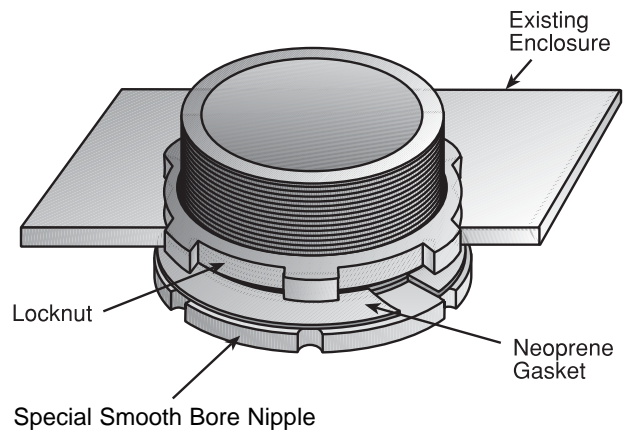

Type GL
Cabinet Adapter
Figure 2

Conduit Sealing Bushings

For Use with Cable in Rigid Conduit*

Type CSB Series Dimensional Data:

Conduit* Size	Max. Diameter of Wire Permitted - Inches (non segmented)				Conduit ID	Dimensions in Inches					
	1 Hole	2 Holes	3 Holes	4 Holes		A Dia.	B	C	D	E	F Min
1½"	.78	.49	.53	.44	1.610	2 ³ / ₈	5/8	7/8	5/16	5/16	1/4
2"	1.02	.77	.71	.61	2.067	2 ¹³ / ₁₄	5/8	7/8	5/16	5/16	1/4
2½"	1.32	.96	.89	.78	2.469	3 ³ / ₈	3/4	7/8	5/16	5/16	1/4
3"	1.89	1.20	1.13	.96	3.068	4 ¹ / ₈	3/4	7/8	5/16	5/16	1/4
3½"	2.13	1.32	1.32	1.13	3.548	4 ⁹ / ₁₆	7/8	7/8	7/16	3/8	1½
4"	2.57	1.63	1.51	1.26	4.026	5 ¹ / ₈	5/16	1	7/16	3/8	1½
5"	3.45	2.00	1.88	1.63	5.047	6 ¹ / ₄	5/16	1	7/16	3/8	1½
6"	4.32	2.51	2.38	2.13	6.065	7 ³ / ₈	5/16	1	7/16	3/8	1½

*Standard fittings may be used with corresponding sizes of schedule 40 pipe or tubes and cored holes which have the same internal diameter as conduit I.D. shown above.

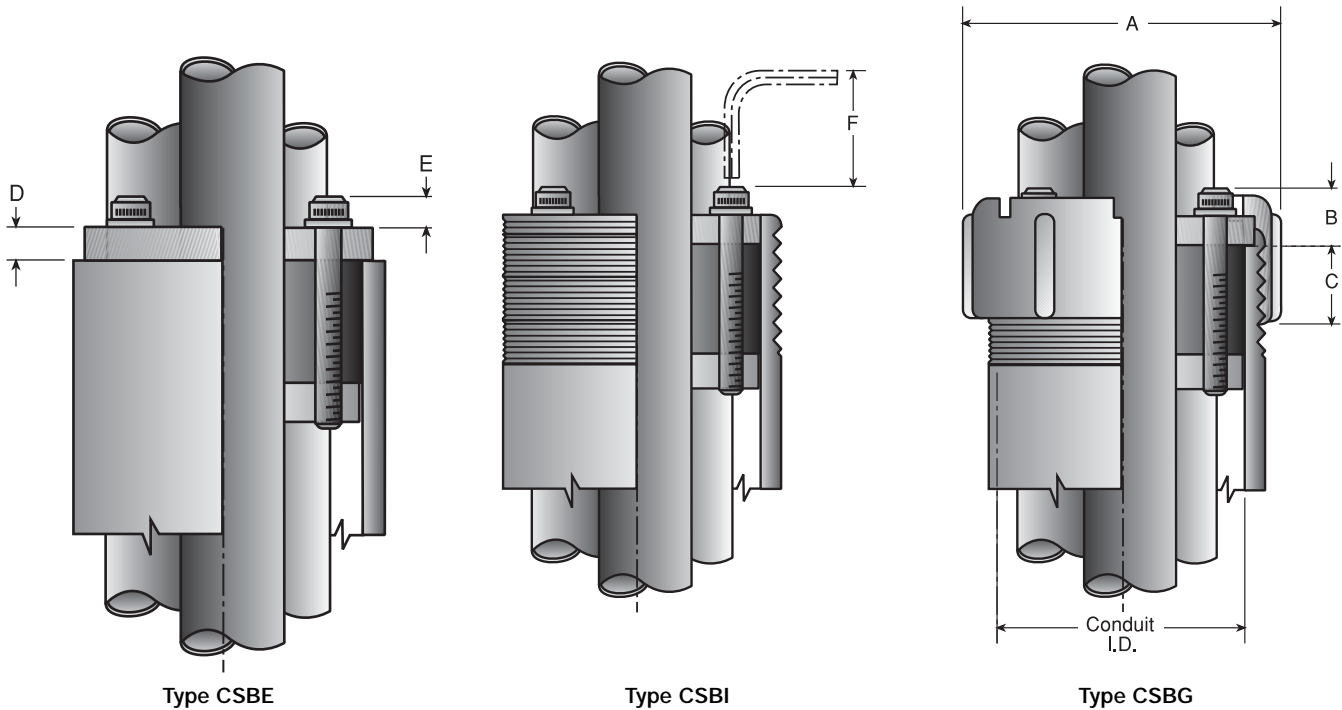

Conduit Sealing Bushings

Typical Applications:

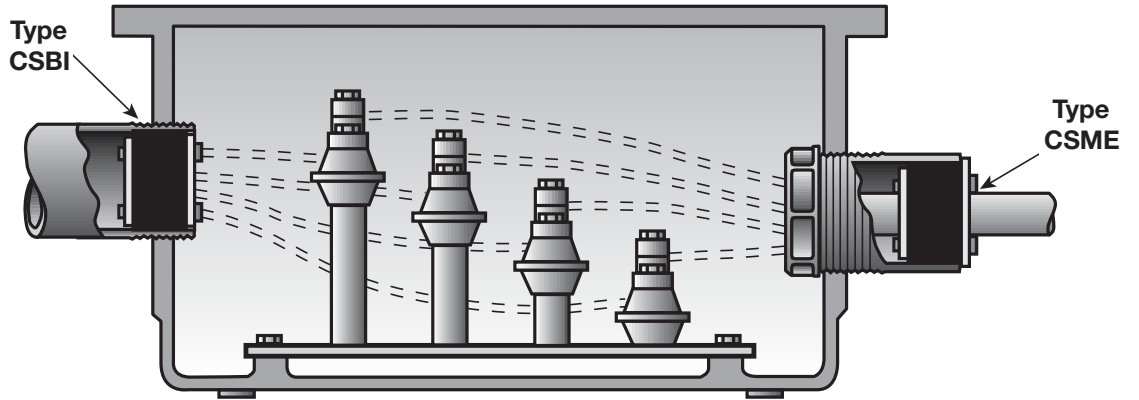

Type CSBI & Type CSME
Used to seal conduits entering an enclosure to prevent condensation and water from entering.

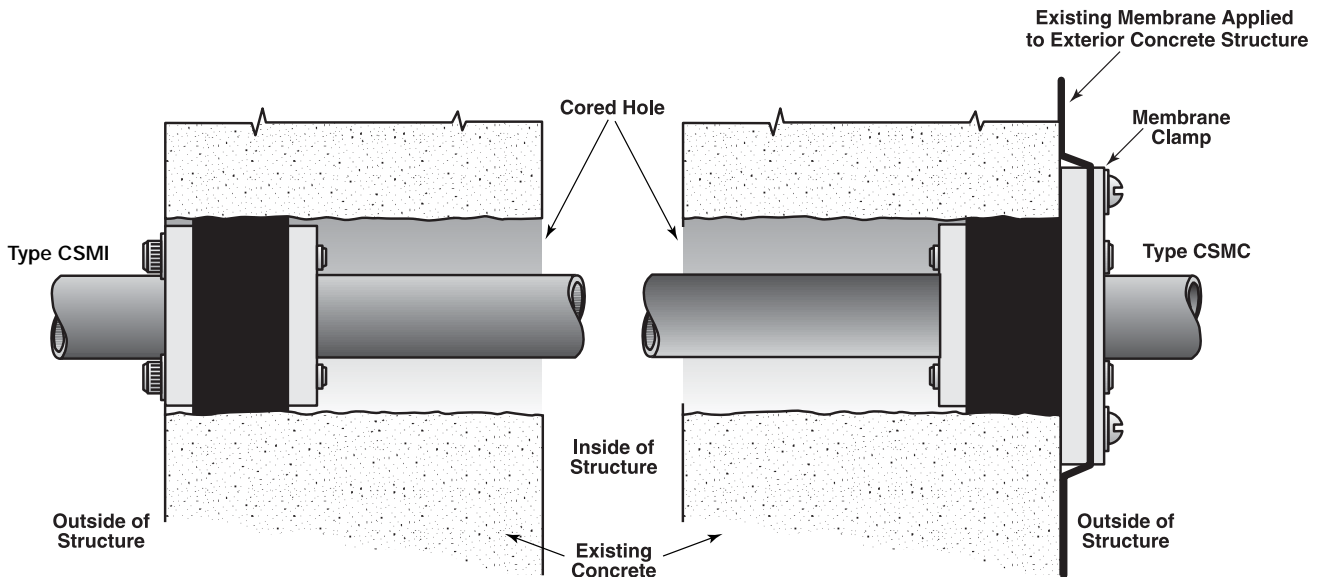

Type CSMI & Type CSMC
Core Drilled Hole Application

Conduit Sealing Bushings

For Use with Pipe, Conduit or Tubing

Type CSM Series

Use:

These Sealing Bushings are used to seal against fluid and gas pressure around mechanical pipes, casing, conduits or tubes. They have the same details of construction and are used for the same applications as the Type CSB Series described on Pages RA17 and RA18. In addition to sealing a pipe within a pipe, some types are specifically designed for use in core bit drilled holes or precast holes in concrete. Most of the options for the Type CSB are available in the Type CSM Series.

Dimensional Data:

See Pages RA22, RA23

TO ORDER SPECIFY:

- 1 Catalog Number
- 2 Diameter of core bit drilled hole, precast hole or I.D. of pipe.
- 3 Number and O.D. of penetrating pipe, conduit or tube
- 4 Disc material finish: PVC Coated Steel Discs (standard); Uncoated Aluminum Discs.
- 5 Segmental design, if required (prices on application)
- 6 Two Neoprene Sealing Rings (if required) Prices on Applications. Suffix G2.

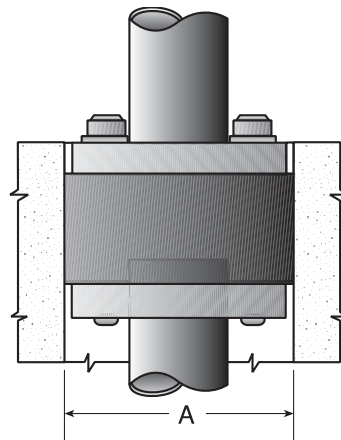

Type CSMI Internal

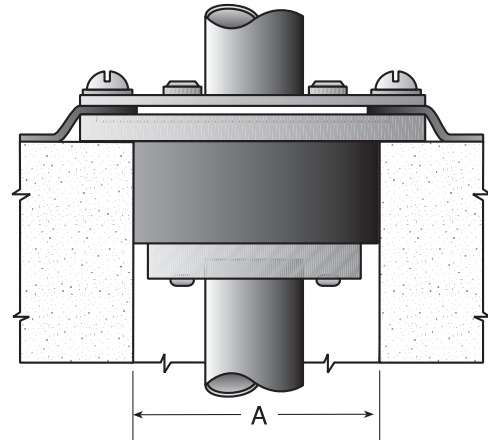

Type CSMC
with steel membrane clamp
for holding existing moisture membrane

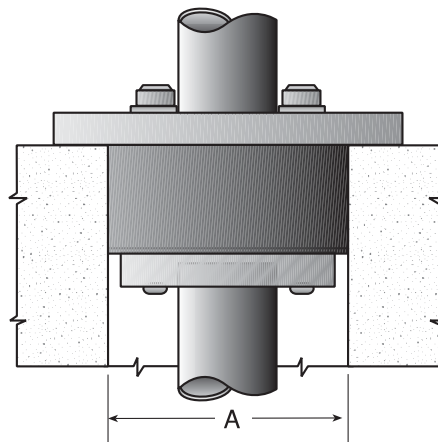

Type CSML Large Top Plate

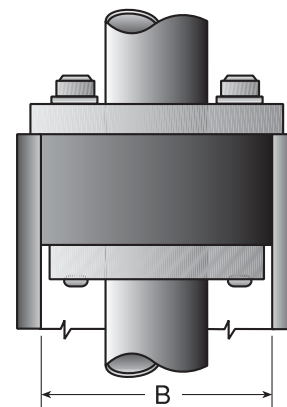

Type CSME External

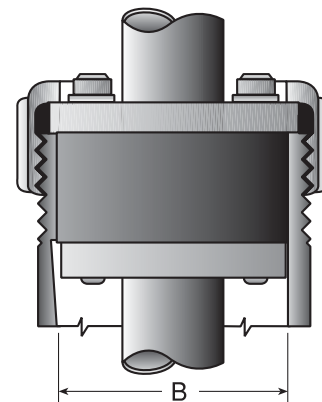

Type CSMG Gland-Locking Collar

Conduit Sealing Bushings

For Use with Pipe, Conduit or Tubing

Type CSM Dimensional Data:

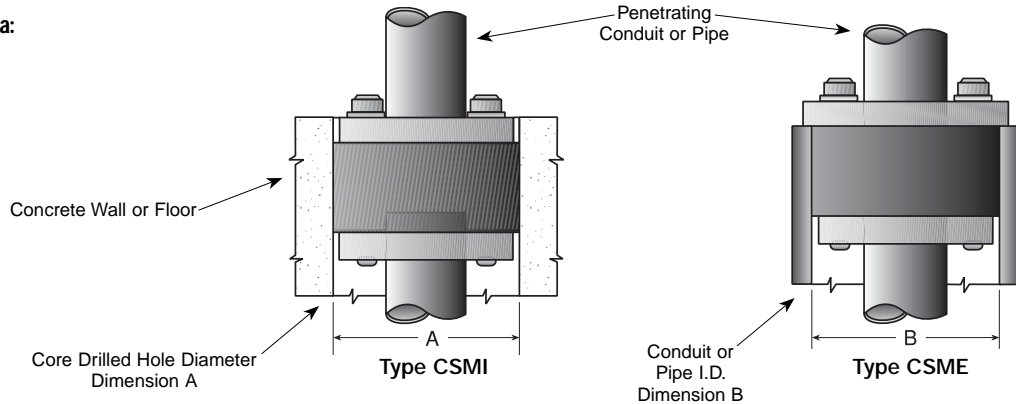

Use with Core Drilled Hole Dia. "A"	Conduit or Pipe I.D. "B"	Single Penetration Applications Dimension in Inches						Multiple Penetration Max. O.D. for More Than One Pipe			Catalog Numbers				
		Steel Pipe or Conduit Nom I.D.	O.D.	Cast Iron Pipe Nom I.D.	O.D.	Copper Tubing Nom I.D.	O.D.	2 Holes	3 Holes	4 Holes	Type CSMI	Type CSML	Type CSMC	Type CSME	Type CSMG
2	2.067	3/8	.675			3/8	.500	.790	.710	.600	CSMI-200P	CSML-200P	CSMC-200P	CSME-200P	CSMG-200P
2 1/2	2.469	1/2	.840			1/2	.625								
		3/4	1.050			3/4	.875								
3	3.068	1	1.315			1	1.125	.970	.930	.730	CSMI-250P	CSML-250P	CSMC-250P	CSME-250P	CSMG-250P
		1 1/4	1.660			1 1/4	1.375								
		1 1/2	1.900			1 1/2	1.625	1.210	1.110	.930	CSMI-300P	CSML-300P	CSMC-300P	CSME-300P	CSMG-300P
						1 3/4	1.875								
3 1/2	3.548		2.000			2	2.125	1.375	1.315	1.125	CSMI-350P	CSML-350P	CSMC-350P	CSME-350P	CSMG-350P
4	4.026	2	2.375	2	2.500	2 1/4	2.375	1.625	1.460	1.315	CSMI-400P	CSML-400P	CSMC-400P	CSME-400P	CSMG-400P
						2 1/2	2.625								
5	5.047	2 1/2	2.875	2	2.750			2.000	1.875	1.625	CSMI-500P	CSML-500P	CSMC-500P	CSME-500P	CSMG-500P
			3.000												
			3.500												
6	6.065	3 1/2	4.000	3	3.660			2.500	2.125	2.000	CSMI-600P	CSML-600P	CSMC-600P	CSME-600P	CSMG-600P
			4.500	3	3.800										
				3	3.960										
8	7.981	4 1/2	5.000	4	4.800										
			5.250	4	5.000										
			5.500					3.000	3.000	2.875	CSMI-800P	CSML-800P	CSMC-800P	CSME-800P	•
		5	5.563												
			6.000												
			6.625												
10	10.020		7.000	6	6.900			Single Penetration Only			CSMI-1000P	CSML-1000P	•	CSME-1000P	•
				6	7.100										
12	11.938		8.000					Single Penetration Only			CSMI-1200P	CSML-1200P	•	CSME-1200P	•
		8	8.625	8	9.050										
				8	9.300										
14	13.126		10.000	10	11.100			Single Penetration Only			CSMI-1400P	CSML-1400P	•	CSME-1400P	•
		10	10.750	10	11.400										
16	15.000		12.000	12	13.200			Single Penetration Only			CSMI-1600P	CSML-1600P	•	CSME-1600P	•
		12	12.750	12	13.500										

The suffix P in the Catalog Number indicates PVC Coated Steel Pressure Discs. For Aluminum Pressure Discs, change P to A.

•Type CSMG and CSMC are not available in these sizes.

† Blank fittings are intended as abandonment and future use devices only. Do not field drill.

NOTE: For additional information on Type CSM Series See Pages RA21, RA 23

Conduit Sealing Bushings

For Use with Pipe, Conduit or Tubing

Type CSM Dimensional Data:

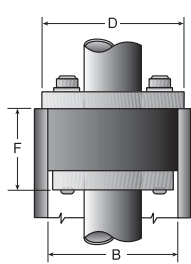

Type CSME

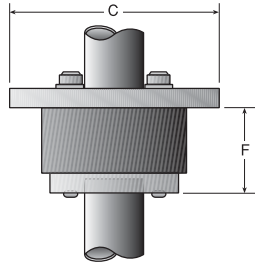

Type CSML

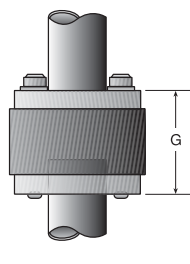

Type CSMI

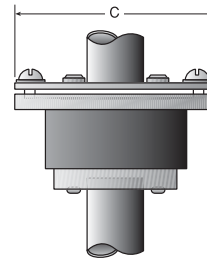

Type CSMC
with steel membrane
clamp

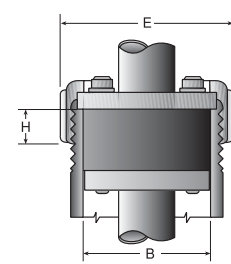

Type CSMG

Use with Core Conduit Drilled or Pipe Hole Dia. I.D. "A" "B"	Single Penetration Applications Dimension in Inches						Catalog No. CSMI - CSML - CSMC - CSME - CSMG -	Multiple Penetration Max. O.D. for More Than One Pipe			C Dia.	D Dia.	E	F	G	H
	Steel Pipe or Conduit Nom I.D.	O.D.	Cast Iron Pipe Nom I.D.	O.D.	Copper Tubing Nom I.D.	O.D.		2 Holes	3 Holes	4 Holes						
2 2.067	3/8 1/2	.675 .840			3/8 1/2	.500 .625	200P	.790	.710	.600	3	2 1/8	2 3/16	1 1/8	1 1/8	5/8
2 1/2 2.469	1	1.315			1	1.125	250P	.970	.930	.730	3 1/2	2 3/16	3 3/8	1 1/8	1 1/8	7/8
3 3.068	1 1/4 1 1/2	1.660 1.900			1 1/4 1 1/2 1 3/4	1.375 1.625 1.875	300P	1.210	1.110	.930	4	3 3/16	4 1/8	1 1/8	1 1/8	7/8
3 1/2 3.548		2.000			2	2.125	350P	1.375	1.315	1.125	4 1/8	3 3/16	4 1/8	1 1/8	1 1/8	7/8
4 4.026	2	2.375	2 2	2.500 2.625	2 1/4 2 1/2	2.375 2.625	400P	1.625	1.460	1.315	5	4 3/16	5 1/8	1 1/8	1 1/8	1
5 5.047	2 1/2 3	2.875 3.000 3.500	2	2.750			500P	2.00	1.875	1.625	6	5 1/4	6 1/4	1 1/8	1 1/8	1
6 6.065	3 1/2 4	4.000 4.500	3 3 3	3.660 3.800 3.960			600P	2.500	2.125	2.000	7 1/8	6 1/4	7 3/8	1 1/8	1 1/8	1
8 7.981	4 1/2 5 6	5.000 5.250 5.500 5.563 6.000 6.625	4 4	4.800 5.000			800P*	--	--	--	9 1/8	--	--	1 1/8	1 1/8	--
10 10.020		7.000	6 6	6.900 7.100			1000P*	--	--	--	11 1/8	--	--	1 1/8	1 1/8	--
12 11.938	8	8.000 8.625	8 8	9.050 9.300			1200P*	--	--	--	13 1/8	--	--	1 1/8	2 1/8	--
14 13.126	10	10.000 10.750	10 10	11.100 11.400			1400P*	--	--	--	15 1/8	--	--	1 1/8	2 1/8	--
16 15.000	12	12.000 12.750	12 12	13.200 13.500			1600P*	--	--	--	17 1/8	--	--	1 1/8	2 1/8	--

*Type CSMG and CSMC are not available in these sizes.

NOTE: For additional information on Type CSM Series See Pages RA21, RA22