

## Vertical Form Fill & Seal

### Application Overview

Vertical Form Fill Seal (VFFS) machines are compact, flexible packaging machines used in a wide variety of products from powdered foods to potting soils and liquids such as water and lotions. Packages take the form of pillow packs to four sided sealed pouches offering consumers attractive and convenient containers.

Key functions are tension control, registration mark capture, synchronized motion, and real-time sealing control.

### Application Requirements

#### Control

- Synchronized axis
- High speed product registration
- Uniform seal and cut
- Flexible package size/type

#### Connectivity

- Simple product change and adjustment
- Versatile communications across hardware
- Help

#### System Costs

- Reduce hardware costs
- Reduce development time

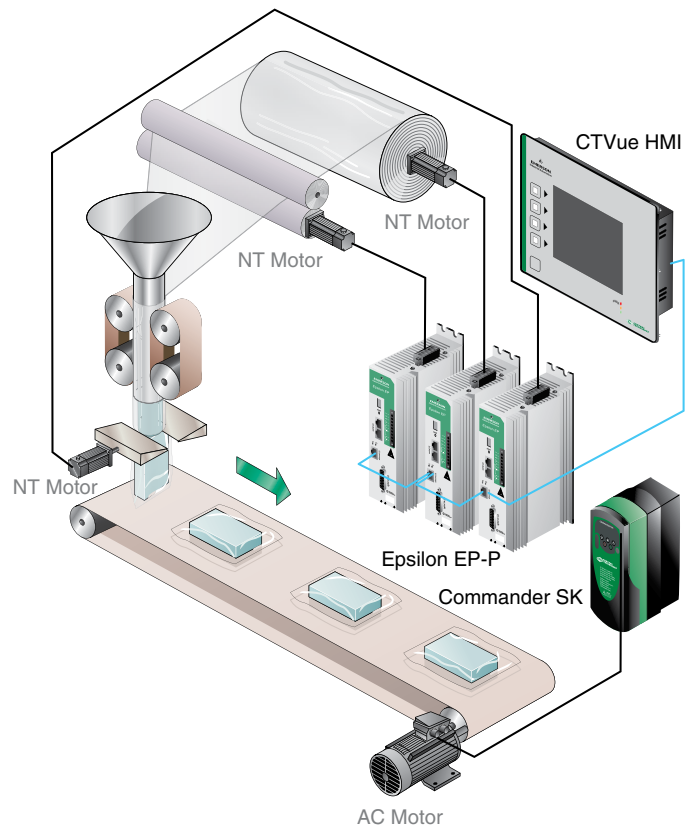

### Control Techniques' Solutions

#### *Servo Drives and Motors, VFDs, and HMIs*

- Programmable electronic camming
- Standard drive to drive cable
- Registration capture to 1µsec.
- Blended moves
- Position mode to torque mode during operation
- Create/load recipes from CTVue HMI



# CONSIDER IT SOLVED™

# Vertical Form Fill & Seal Solutions

## Control Techniques' Performance Advantages

### Built-in Functions

- High speed registration
- Blended moves
- Position to torque mode during operation

### Advanced Control and Tuning

- Electronic cams
- Real time programs
- Real time timers for precise control

### Software

- Power Tools Pro
- Free software
- Intuitive

### Distributed Control

- Programmable drive
- Drive to Drive communications
- Ethernet or RS485

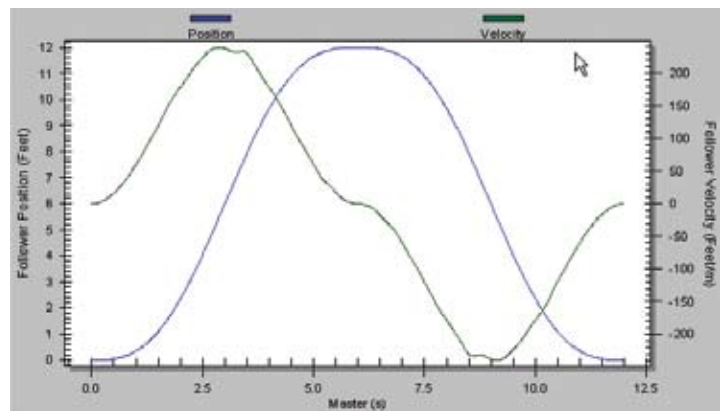
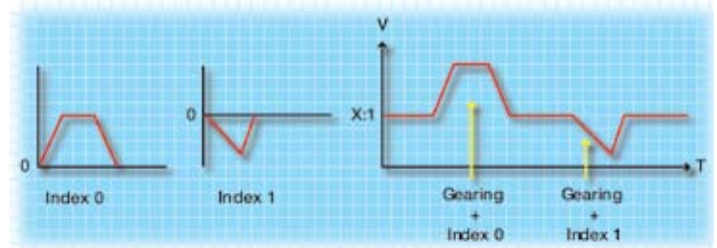

Cubic-Spline	Master (s)	Follower (Feet)	Interpol
17	4.000000	9.0900	5 Cubic
18	4.320000	10.5100	5 Cubic
19	4.560000	11.0200	5 Cubic
20	4.800000	11.4100	5 Cubic
21	5.040000	11.6900	5 Cubic
22	5.280000	11.8600	5 Cubic
23	5.520000	11.9600	5 Cubic
24	5.760000	11.9950	5 Cubic
25	6.000000	12.0000	5 Cubic
26	6.240000	11.9950	5 Cubic
27	6.480000	11.9600	5 Cubic
28	6.720000	11.8600	5 Cubic
29	6.960000	11.6900	5 Cubic
30	7.200000	11.4100	5 Cubic
31	7.440000	11.0200	5 Cubic

## World Class Products & Support

- Worldwide Application & Field Service Network
- 24/7 support line 1-800-893-2321



Compact Servo Drives



AC Drives



Intelligent Servo Drives

